

Semester One
Examination 2019
Question/Answer booklet

PHYSICS UNIT 1

Student Name: _____

Teacher Name: _____

Time allowed for this paper:

Reading time before commencing work: 10 minutes

Working time for paper: 3 hours

Materials required/recommended for this paper

To be provided by the supervisor

This Question/Answer Booklet

Formulae and Data Booklet

To be provided by the candidate

Standard items: pens, pencils (including coloured), sharpener, correction fluid, eraser, ruler, highlighters.

Special items: up to three non-programmable calculators approved for use in the WACE examinations, drawing templates, drawing compass and a protractor.

STRUCTURE OF THIS PAPER

Section	No. of Questions	No. of questions to be attempted	Suggested working time (minutes)	Marks available	Percentage of exam
Section one Short Response	11	ALL	55	54	30
Section two Problem Solving	6	ALL	95	90	50
Section three Comprehension	2	ALL	30	36	20
Total				180	100

INSTRUCTIONS TO CANDIDATES

Write your answers in the spaces provided beneath each question. The value of each question (out of 180) is shown following each question.

Answers to questions involving calculations should be evaluated and given in decimal form. Final answers should be given up to three significant figures and include appropriate units.

Questions containing the instruction "**estimate**" may give insufficient numerical data for their solution. Give final answers to a maximum of two significant figures and include appropriate units.

Despite an incorrect final result, credit may be obtained for method and working providing these are clearly and legibly set out.

Questions containing specific instructions to **show working** should be answered with a complete, logical, clear sequence of reasoning showing how the final answer was arrived at; correct answers which do not show working will not be awarded full marks.

Section One: Short Response

30% (54 marks)

This section has 11 questions. Answer **all** questions. Answer the questions in the spaces provided.
Suggested working time: 50 minutes.

Question 1

(3 marks)

Aiden is measuring the following shaded perfect circle and he puts a ruler next to it, as shown on the right.

Write the absolute and relative uncertainties of the diameter of the circle below.

a) Diameter with absolute uncertainty:

b) Diameter with relative uncertainty:

Space for working out:

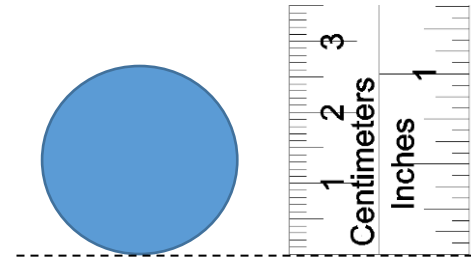

Question 2

(3 marks)

A glider, as shown on the right, is a light aircraft that is designed to fly without using an engine over a large plain field. As the field is heated by the sun, it is able to operate more effectively. Explain the reasons using Physics concepts.



Question 3**(5 marks)**

Sodium-24 has a half-life of 15.0 hours. It has applications in medicine and engineering.

- a) How much of a 34.0 g sample of Sodium-24 will remain undecayed after two days? Show clear working. (3 marks)

- b) If Iodine-131 (half-life = 8.00 days) of the same amount were to replace Sodium-24, would more of the original sample be left over or less compared to Sodium-24? Explain without calculations. (2 marks)

Question 4**(4 marks)**

A hot body is brought into contact with a colder body until their temperatures are the same. Assume that no other bodies are nearby.

- (a) Is the energy lost by one body is equal to the energy gained by the other? Explain your answer. (2 marks)
- (b) Is the temperature drop of one body equal to the temperature rise of the other? Explain your answer. (2 marks)

Question 5

(7 marks)

A food shop sells hot beef soup. A number of slices of beef are put into a bowl, followed by pouring in a hot liquid vegetable stock. The soup is then ready to serve to customers.

Use the following information to answer the questions:

- Mass of vegetable stock: 0.800 kg
- Initial temperature of the stock: 96.0 °C
- Specific heat capacity of the stock: 4000 J kg⁻¹ K⁻¹
- Mass of each beef slice: 50.0 g
- Initial temperature of beef: 6.00 °C
- Specific heat capacity of beef: 3000 J kg⁻¹ K⁻¹



- a) According to safety regulations, the serving temperature of the soup should be below 60.0 °C. Estimate the minimum number of beef slices required to add to the stock to achieve this.

(6 marks)

- b) State one assumption in the calculation in part a).

(1 mark)

Question 6

(7 marks)

The diagram below shows a neutron, **n**, being absorbed by a Uranium-235 atom. The remaining neutrons then continue to react with other Uranium-235 atoms.

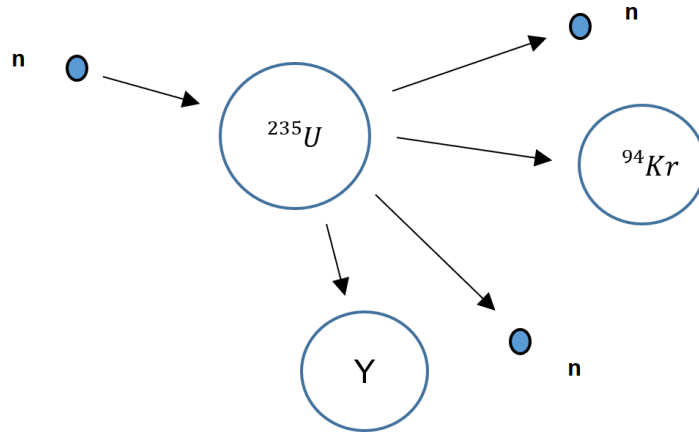

- a) Complete the following table by writing the correct terminologies: (3 marks)

Descriptions	Terminologies
A neutron collides with a Uranium nucleus and is absorbed.	
The atom splits into different two atoms and two neutrons.	
The released neutrons continue to be absorbed by other Uranium-235 nuclei.	

- b) Predict what substance **Y** be. Write the symbol of the substance, its atomic number and mass number in a correct format. (2 marks)
- c) If the Krypton-94 continues to decay and release a beta negative particle. Write the full nuclear equation for this decay. (2 marks)

Question 7

(5 marks)

The diagram below is a simple schematic diagram of a fridge. It consists of one long coil that goes through the inside compartment of the fridge and then flows outside. Fluid refrigerant is sealed inside this coil. The arrow, in the diagram below, shows the direction of the refrigerant. Part C is called an expansion valve. The pressure inside the pipe is reduced by the expansion valve, causing the refrigerant to evaporate.

a) Explain how this helps to cool the fridge.

(3 marks)



b) When there is a power outage, a fridge can still keep the contents cold for as long as 2 hours.

Describe the features of a fridge which help to keep the fridge cold.

(2 marks)

Question 8

(6 marks)

When we discuss radiation doses, there are essentially two different types of “doses”; *absorbed dose* and *dose equivalent*.

- (a) Explain the difference between absorbed dose and dose equivalent? (2 marks)

The table below shows the dose equivalent for several common medical scans.

Procedure	Approximate dose equivalent (mSv)	Comparable to natural background radiation for
CT – Abdomen and pelvis	10	3 years
CT – Abdomen and pelvis, repeated with and without contrast	20	7 years
CT – Colonoscopy	6	2 years
Intravenous Pyelogram	3	1 year
Barium enema (Lower GI X ray)	8	3 years
Upper GI study with Barium	6	2 years

- (b) Suppose a 50.0 kg person is having a CT-colonoscopy, with the radioisotope used being a slow neutron emitter. Determine the absorbed radiation dose **AND** the total energy absorbed? (3 marks)
- (c) Background radiation includes radiation comes from environmental sources including the earth's crust, the atmosphere, cosmic rays, and radioisotopes. CT – Abdomen and pelvis, repeated with and without contrast, has a high background radiation equivalence. Suggest a type of radiation that could produce such a high equivalence.

(1 mark)

Question 9

(5 marks)

The graph below shows the decay of radiative substance **Z**.

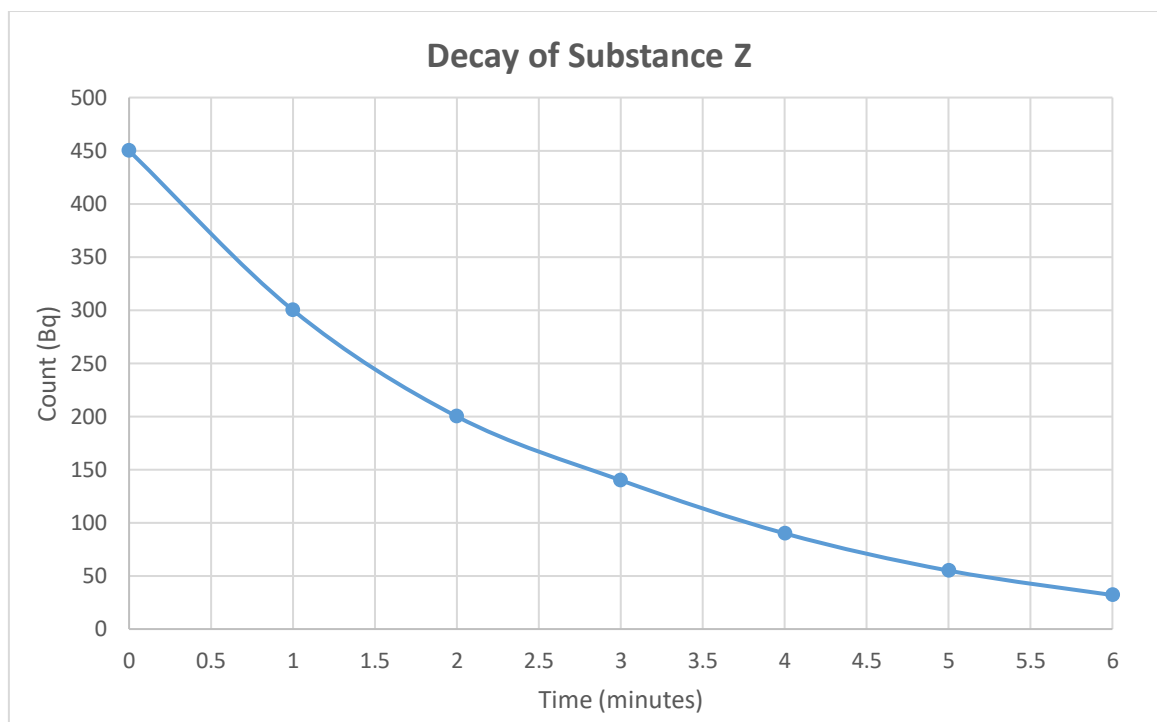

a) Use the graph above to estimate the half-life of substance **Z**. Show your working on the graph above. (2 marks)

b) Hence, estimate how long it would take for substance **Z** to decrease to 10.0 Bq of activity. (3 marks)

Question 10**(5 marks)**

Find the binding energy, per nucleon in, MeV, for Uranium-236.

Use the following data:

Mass of proton	=	1.00727 u
Mass of neutron	=	1.00867 u
Mass of Uranium-236	=	236.045568 u

Question 11**(4 marks)**

Calculate how much energy needs to be removed to convert 500 g of water from 24.0° C into ice at – 4.00° C ice.

Section Two: Problem-solving

50% (90 marks)

This section contains 6 questions. Answer **all** questions. Answer the questions in the spaces provided. Suggested working time 90 minutes.

Question 12

(16 marks)

John carries out an experiment to investigate the cooling properties of Octadecan-1-ol. Octadecan-1-ol is one type of alcohol that can be used in anti-freeze products and lubricants. Its latent heat of fusion is 331 J kg^{-1} .

John heats a test tube containing of 250 g solid Octadecan-1-ol in a water bath at 80.0°C . He then puts the test tube immediately into a beaker of iced water.

The temperature of the Octadecan-1-ol is then recorded over a time interval of 5.00 minutes. The results are shown below:



Time (s)	0	30	60	90	120	150	180	210	240	270	300
Temperature ($^\circ\text{C}$)	71	63	57	55	55	55	55	55	50	44	35

- a) Plot a cooling curve of Octadecan-1-ol in the graph below. A spare graph paper can be found on page 31.

(2 marks)

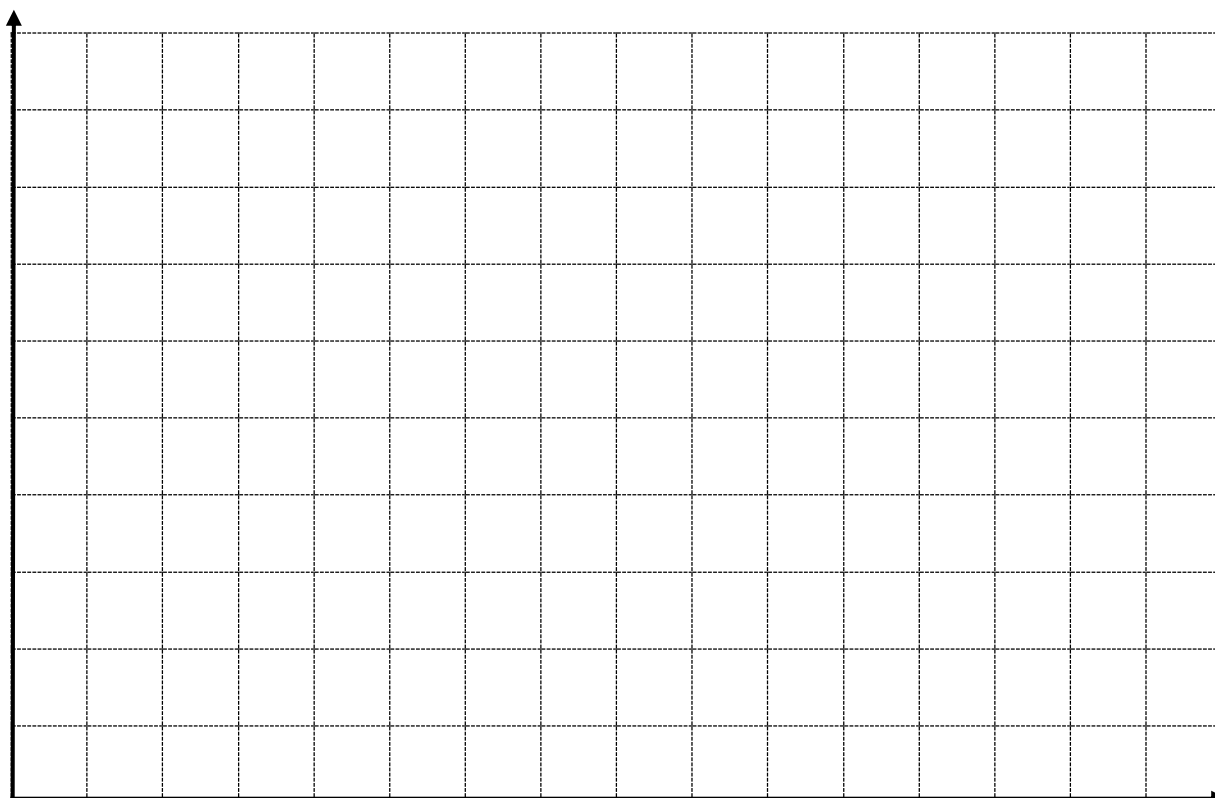

- b) Estimate the melting point of Octadecan-1-ol, in Kelvin.

(2 marks)

- c) Use kinetic theory to explain the shape of the curve between 90 seconds and 210 seconds. (3 marks)
- d) Use the given information to calculate the rate of heat loss of the 250 g of Octadecan-1-ol in between 90 seconds and 210 seconds. (4 marks)
- e) If the experiment was to be done in thermally insulated conditions, would your answer for part d) be higher or lower? Explain your answer. (3 marks)
- f) List one possible example of random error and one possible example of systematic error in this experiment. (2 marks)

Random error: _____

Systematic error: _____

Question 13

(13 marks)

In a juice factory, a radioactive source and a Geiger-Muller (GM) counter are used to ensure each box of juice is full before delivering to the shops. The radiation emitted by the source penetrate through the top section part of each box and are then detected by the GM counter as shown in the following diagram.

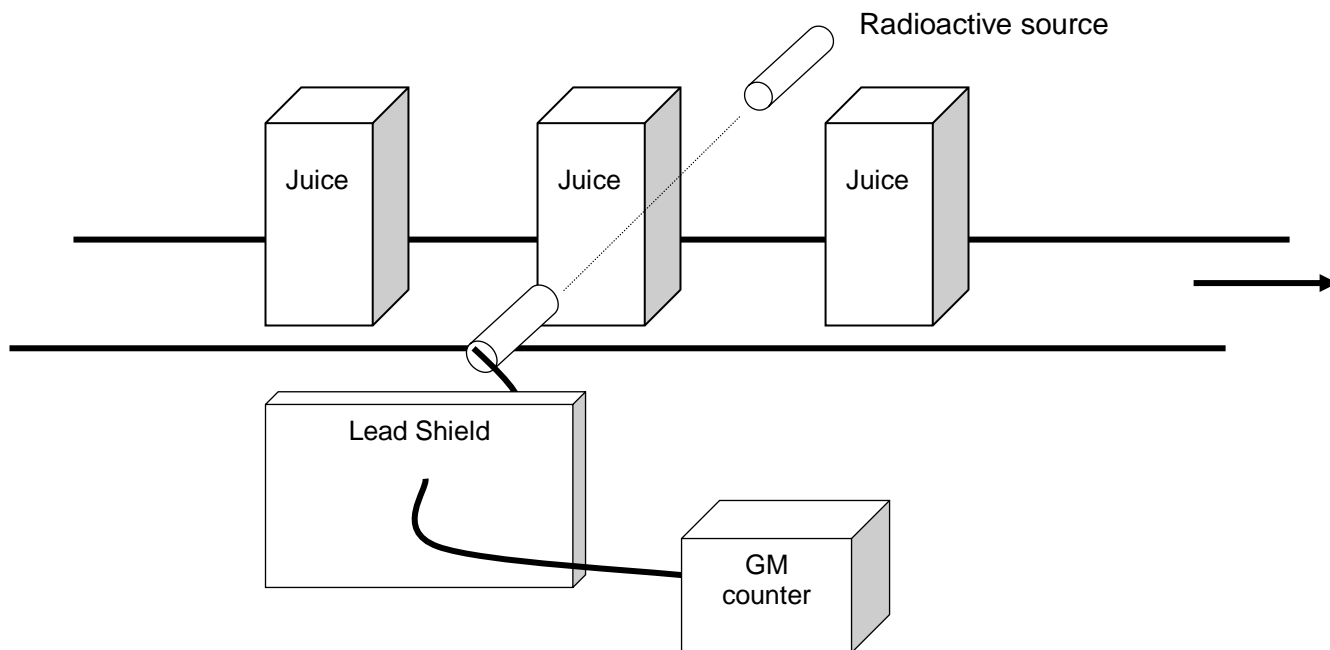

The following table shows a sample of results recorded by the GM counter:

Box Number	1	2	3	4	5
Measured count rate (Bq)	645	652	648	729	654

- a) What type of radiation (alpha, beta or gamma) should be used for the radioactive source? Explain. (2 marks)
- b) Why was there an increase in the measured count rate when the fourth box of juice passes through the detector? Explain your reason. (2 marks)

- c) It is claimed that as long as the radiation penetrate through the top part of the juice box and are detected by the GM counter, the distance between the source and the detector is **NOT** critical. Comment on this statement. (2 marks)
- d) i) If you were the manager of the factory and had a choice of half-lives of the radioactive source shown below. Which one would you choose? Circle your answer. (1 mark)
- 10 seconds** **10 hours** **10 years**
- ii) Briefly explain your answer of your above choice. (1 mark)
- e) Comment on the purpose of the lead shield. (1 mark)
- f) All factory workers who work in this juice factory must wear radiation monitoring badges. These badges monitor the radiation exposure to a factor worker. A person whose mass is 75.0 kg receives an average of 3.00 J a day according to the badge. Estimate the dose equivalent this person receives every day. Use your answer in part a) for the calculation. (4 marks)
-

Question 14

(18 marks)

The isotope tritium (hydrogen-3) has a radioactive half-life of 12 days.

(a) State what is meant by the term "isotope". (2 marks)

(b) Define radioactive half-life. (1 mark)

Tritium may be produced by bombarding a nucleus of the isotope lithium-7 with a high-energy neutron. The reaction equation for this interaction is:

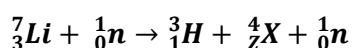

(c) Identify the atomic number, Z, of X. (1 mark)

(d) Use the following data to show that the minimum energy that a neutron must have to initiate the reaction in (c) is about 2.5MeV.

(3 marks)

Rest mass of lithium-7 nucleus =7.0160 u

Rest mass of tritium nucleus =3.0161 u

Rest mass of X nucleus =4.0026 u

(e) A nucleus of tritium decays to a nucleus of helium-3. Identify the particle X in the nuclear reaction equation for this decay shown below.

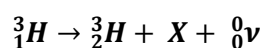

(1 mark)

A sample of tritium has an activity of 8.0×10^4 Bq at time $t=0$ and the half-life of tritium is 12 days.

- (f) Using the axes below, construct a graph to show how the activity of the sample varies with time from $t = 0$ to $t = 84$ days. (5 marks)

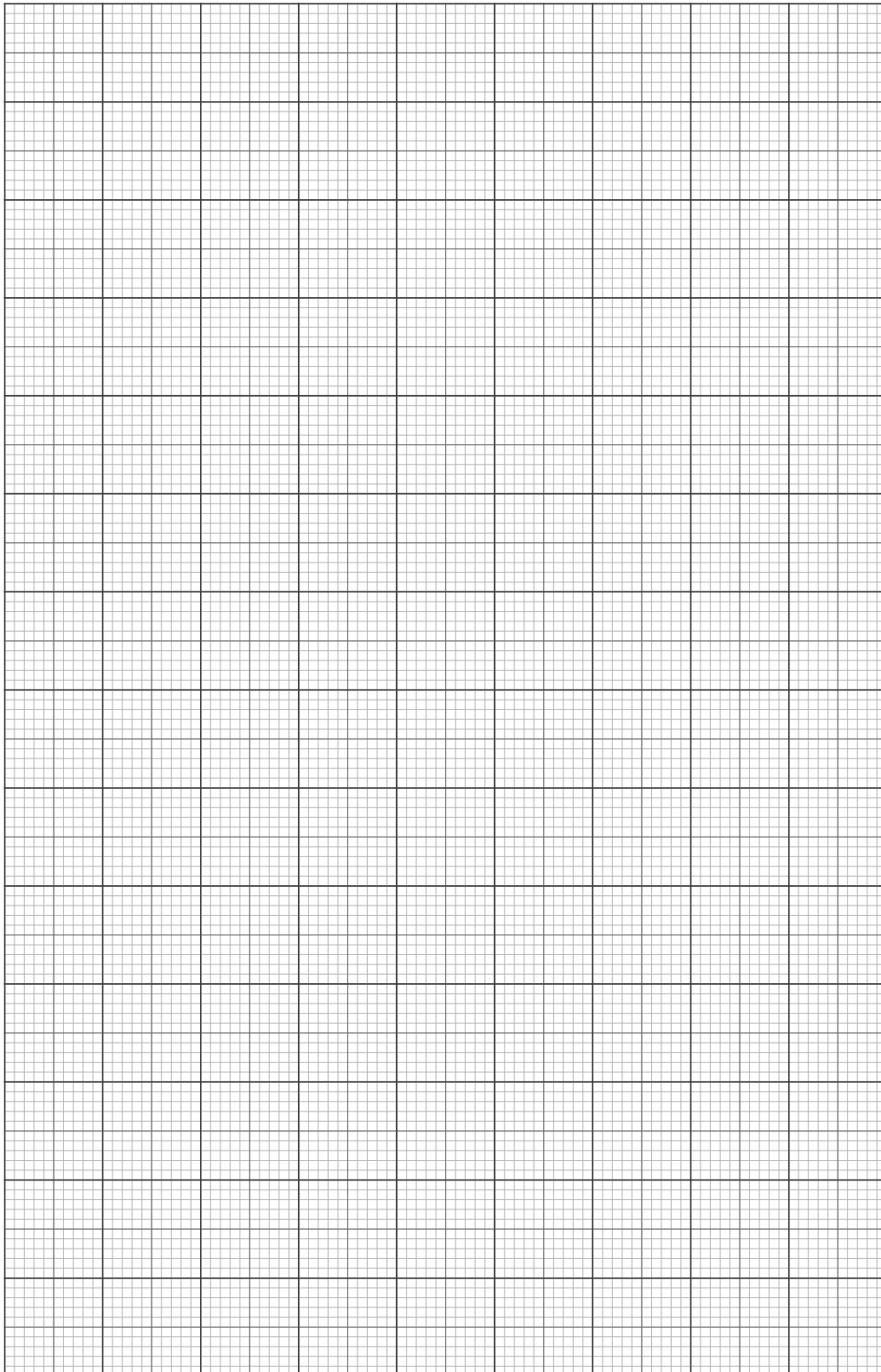

- (g) Use the graph to determine the activity of the sample after 30 days. (2 marks)
- (h) The activity of a radioactive sample is proportional to the number of atoms in the sample. The sample of tritium initially consists of 1.2×10^{11} tritium atoms. Determine, using your answer to **(g)** the number of tritium atoms remaining after 30 days. (3 marks)
-

Question 15

(13 marks)

On average, a person, through perspiration, loses up to 400 mL of water every hour even sitting in an comfortable office. The latent heat of vaporisation of water at a comfortable temperature is $2.42 \times 10^6 \text{ J kg}^{-1}$. Note: density of water is 1.00 kg L^{-1}



- a) Explain how water assists heat loss for human bodies to prevent hyperthermia, a scientific term to describe a body temperature above 40.0°C . (3 marks)
- b) Jane, whose mass is 55.0 kg, has been at work for 8.00 hours.
- i) How much heat energy does Jane's body lose at work, through the evaporation of water? Assume the evaporating perspiration does not absorb heat from anywhere else. (3 marks)
- ii) By how much would Jane's body temperature rise if the same amount of water in part i) did not evaporate from her skin? Assume the specific heat capacity of a human body is $3500 \text{ J kg}^{-1} \text{ K}^{-1}$. (2 marks)
-

c) Jane finds that using a fan which blows air across her skin helps her feel more comfortable while working in a hot office. Explain why. (3 marks)

d) After work, Jane goes to a swimming pool. Explain why she often feels colder when she gets out of the water, even if the temperature of the air and the water are the same. (2 marks)

Question 16

(14 marks)

The Pobeda ice island in Antarctica is created and vanishes periodically. It is created by the calving of an enormous block of ice from Denman Glacier. The resulting iceberg drifts until it runs aground upon a shoal north of the ice shelf. The iceberg remains locked in this position for a decade or more, until it has remodelled enough to free itself from the shoal. It then drifts into the open ocean, where it breaks into fragments. These iceberg fragments eventually melt as they drift into warmer waters.



Use the following **additional data** to answer the questions that follow.

Typical dimensions of surface of the island	= 70 km×35 km
Typical height of island	= 240m
Average temperature of the island	= -35 C°
Mass of 1.0 m ³ of sea ice	= 920 kg

- (a) Distinguish, with reference to molecular motion and energy, between solid ice and liquid water. (4 marks)
- (b) Given the dimensions of the island and the data above, show that the mass of Pobeda island is about 5.4×10^{14} kg? (2 marks)

- (c) Show that the energy required to melt the island to form water at 0 C° is about $2.0 \times 10^{20}\text{ J}$. Assume that the top and bottom surfaces of the island are flat and that it has vertical sides.

(3 marks)

- (d) The Sun supplies thermal energy at an average rate of 450Wm^{-2} to the surface of the island. Estimate the time taken to the nearest year to melt the island and list any assumptions that you make.

(5 marks)

Question 17

(16 marks)

The Sun constantly undergoes a series of fusion reactions to produce a large amount of energy. A common series of reactions that occurs within the sun is outlined in the steps below.

1. Two protons fuse together, producing Deuterium and other particles plus energy;
2. Deuterium and a proton fuse, producing Helium-3 and energy;
3. Two Helium-3 nuclei fuse together, producing Helium-4, two protons, and energy;
4. Helium-3 fuses with Helium-4, producing Beryllium-7, which decays and then fuses with another proton to yield two Helium-4 nuclei plus energy.

Use the following data to answer the questions below:

Element	Scientific name	Mass (u)
1_1H or 1_1p	Protium/Proton	1.008
2_1H	Deuterium	2.015
3_1H	Tritium	3.015
3_2He	Helium-3 (Helion)	3.016
4_2He	Helium-4	4.003
1_0n	Neutron	1.008

- a)
- i) For step 3, write the full nuclear equation for the process. (2 marks)

 - ii) Use the information above to calculate the energy released, in MeV, for step 3 (part i)). Correct the answer to two significant figures. (5 marks)

- iii) Calculate the total energy, in Joules, that would be produced from 50.0 Tonnes of Helium-3 undergoing the reaction in Step 3. Correct your answer to two significant figures. (5 marks)
- b) Helium-4 is more stable than Tritium. Comment on this statement. (2 marks)
- c) The Sun's life span is about 5 billion years. Would the mass of the sun have increased or decreased by then? Explain. (2 marks)

END OF SECTION TWO

Section Three: Comprehension

15% (36 marks)

This section has two questions. Answer **both** questions. Answer the questions in the spaces provided. Suggested working time: 40 minutes.

Question 18

(16 marks)

“Decades after bomb making, the radioactive waste remains dangerous”. (Inside Science Sept 28, 2018)

Nearly 30 years ago, the state of Washington and two federal agencies agreed to clean up the Hanford Nuclear Reservation, a 586-square-mile chunk of sagebrush desert where the U.S. produced plutonium for nuclear weapons starting 75 years ago. In the process, some 56 million gallons of concentrated, radioactive sludge and crystallized salts sit corroding within 177 steel-and-concrete underground tanks.



An atmospheric nuclear test carried out on April 18, 1953. Such bombs made use of plutonium-239, and the government is still trying to figure out what to do with the waste created by its production. (Credit: National Nuclear Security Administration/Nevada Site Office)

Although the tank waste is only a fraction of the total, its safe disposal is one of the site's most urgent priorities. Eighteen years ago, workers began constructing a plant for “immobilizing” the remaining waste by vitrifying it — a process whereby it is mixed with molten glass, cooled and encased in stainless steel canisters for long-term storage underground in an as yet undesignated location.

Today the task remains unfinished.

How Did This Happen?

Construction of the world's first plutonium production reactor began at the site in 1943. During World War II and throughout the Cold War, the U.S. made some 67 metric tons of plutonium at Hanford. Its reactors bombarded uranium-238 with neutrons to produce uranium -239. This undergoes further decays to produce plutonium-239, the isotope best suited to producing big controlled explosions like the Fat Man bomb that burst over Nagasaki in 1945.

Every bombardment produced a chain of fission products, each with its own half-life and decay chain. The extremely long half-life of some of these by-products (tens of thousands of years) dictates that the waste must be contained for longer than most humans can imagine, let alone ensure its active management. But the problem is not just radiation: The waste's chemistry, too, can make the problem appear insoluble.

Scary — But How Dangerous?

The thought of both radiation and toxic chemicals tends to make people uneasy. And according to David Clark, who studies plutonium (Pu-239, half-life 24,100 years) at Los Alamos National Laboratory, most people fear the element because of its association with nuclear weapons. However, if it's not in a bomb or misbehaving at a nuclear power plant, it's generally only harmful if a person ingests or inhales it. Two other, more concerning, fission products, cesium-137 (half-life about 30 years) and strontium-90 (half-life almost 29 years), will constitute the greatest amount of radioactivity in the Hanford waste for the next century. These two elements created so much heat in the tanks that much, but not all, of their mass has been removed to canisters kept cool underwater elsewhere at the site until the vitrification plant begins treating high-level waste. Currently that startup date is 2036.

Although the whole point of Hanford was to enrich plutonium for use elsewhere, there is still enough left in the waste, dense and insoluble, to make some experts nervous. It only takes about 10 kilograms to start a chain reaction. In 2012, most construction of the vitrification plant was suspended after the

General Accountability Office released a highly critical report, and two years after the Defense Nuclear Safety Board expressed strong concern that enough plutonium might collect somewhere in the plant — in the giant melters where the waste is mixed with molten glass-forming minerals, in the million feet of piping, or elsewhere — to initiate a chain reaction.

Not Your Mother's Nuclear Waste

Nuclear power plant waste is successfully vitrified in many countries — but in most, only one chemical separation process to create fuel is used, whereas Hanford employed three major processes and several variations. And in terms of vitrification, the influence of chemistry far outstrips that of radiation. “It’s all the other elements that cause the trouble — so much so that “textbook chemistry doesn’t work at Hanford,” said Hanford chemist Vince Panesco in remarks to a February 2018 National Academy of Sciences panel.

Whalen agrees. “You’ve got thousands of compounds and the chemistry is constantly changing,” she said. **“They’ve already formed a lot of compounds that were never originally put in the tanks.”**

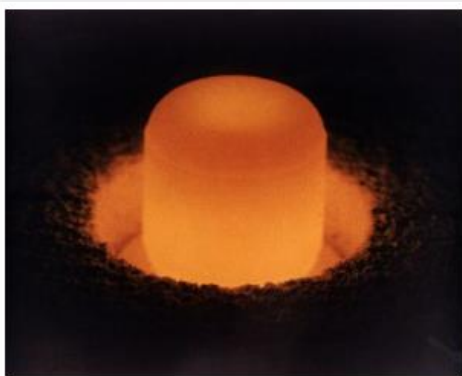

A pellet of plutonium-238, glowing under its own light. This particular isotope is often used as a power source for spacecraft.
(Credit: U.S. Department of Energy)

Radionuclides, We Hardly Know

In addition to the heavier elements, the regulators require technetium-99 (half-life 211,000 years) and iodine-129 (half-life 15.7 million years) to be controlled. Unlike the heavy metals, both of these are highly soluble and highly volatile, which means they can escape solids and liquids. During vitrification, the temperatures required to melt the glass will be high enough for them to depart the melt. They must be captured and returned to the waste stream at some point.

Technetium-99 has created a radiochemical mystery.

According to Clark, chemists assumed that it would react with oxygen to form pertechnetate, which they knew they could remove with what are called ion exchange columns. That would solve the problem of technetium escaping. But that’s not what all the technetium did: A considerable percentage formed a still-unidentified compound that the ion exchange columns don’t capture.

- (a) Explain what is meant by the process of “vitrifying” the radioactive materials?
(1 mark)
- (b) How is it possible to produce plutonium-239 from uranium-238?
(2 marks)
-

- (c) Explain what the author means by “*Every bombardment produced a chain of fission products, each with its own half-life and decay chain*”?
(4 marks)
- (d) Why must the waste be contained for such a long period of time?
(1 mark)
- (e) Suggest a reason why Pu-239 is “*generally only harmful if a person ingests or inhales it*”?
(2 marks)
- (f) Explain how an accidental chain reaction could theoretically occur in the plant?
(2 marks)
-

- (g) The author states that "*They've already formed a lot of compounds that were never originally put in the tanks*". Explain how this is possible? (2 marks)
- (h) In the vitrification process, what were some of the issues concerning the vitrification of technetium-99 and iodine-129? (2 marks)
-

Question 19

HOUSEHOLD INSULATION

(20 marks)

Heat is transferred from one place or object to another in three different ways: by conduction, by convection, and by radiation. This question deals with conduction.

When a metal poker is put in a hot fire, or a silver spoon is placed in a hot bowl of soup, the exposed end of the poker or spoon soon becomes hot as well, even though it is not directly in contact with the source of heat. We say that heat has been conducted from the hot end to the cold end.

Heat conduction in many materials can be visualized as being carried out via molecular collisions. As one end of an object is heated, the molecules there move faster and faster (higher temperature). As these faster molecules collide with slower-moving neighbours, they transfer some of their kinetic energy to them, which in turn transfer some energy by collision with molecules still farther along the object. Thus the kinetic energy of thermal motion is transferred by molecular collision along the object. In metals, collisions of free electrons are mainly responsible for conduction. Conduction between objects in physical contact occurs similarly.

Heat conduction from one point to another takes place only if there is a difference in temperature between the two points. Indeed, it is found experimentally that the rate of heat flow through a substance is proportional to the difference in temperature between its ends. The rate of heat flow also depends on the size and shape of the object. To investigate this quantitatively, let us consider the heat flow through a uniform cylinder, as illustrated below.

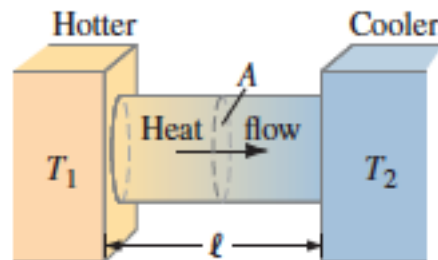

It is found experimentally that the heat flow Q over a time interval is given by the relation

$$\frac{Q}{t} = kA \frac{T_1 - T_2}{l}$$

where A is the cross-sectional area of the object, l is the distance between the two ends, which are at temperatures T_1 and T_2 , and k is a proportionality constant called the **thermal conductivity** which is characteristic of the material.

(a) Explain the difference between “heat” and “temperature” ?

(2 marks)

(b) Using the equation above, determine the S.I. units for thermal conductivity.

(2 marks)

- (c) Explain what is meant by saying that the thermal conductivity is “*characteristic of the material*”?

(1 mark)

- (d) If k is large for a material, what would that indicate about how well it conducts thermal energy?

(1 mark)

Two students decided to conduct an experiment to determine the thermal conductivity of glass, typical to what you might find in the windows at home.

For this experiment, they used panes of glass 20.0 cm high and 15.0 cm wide and of varying thickness. The inside of each glass pane was kept at a constant temperature of 40.0°C and the outside of each glass pane at a constant 26.0°C. A joulemeter was used to measure the thermal energy transferred in each one minute run of the experiment.

The results of the experiment are shown below.

Thickness of glass, l , $\times 10^{-3}$ (m)	Thermal energy transferred, Q , (J)	Thermal energy transferred per second, Q/t ()	$1/l$ ()
1.0	211.7		
2.0	105.8		
3.0	70.6		
4.0	52.9		
5.0	42.3		
6.0	35.3		
7.0	30.2		
8.0	26.5		
9.0	23.5		
10.0	21.2		

- (e) What could have been done in order to increase the reliability of the results? (1 mark)
- (f) For this experiment: (3 marks)
- (i) What was the dependent variable?
- (ii) What was the independent variable?
- (iii) What were some variables that were/should have been controlled?
- (g) Complete the two incomplete columns in the table and include units. (2 marks)
-

- (h) On the following graph paper, draw a graph that shows the relationship between Q/t on the vertical axis and $1/l$ on the horizontal axis. (4 marks)

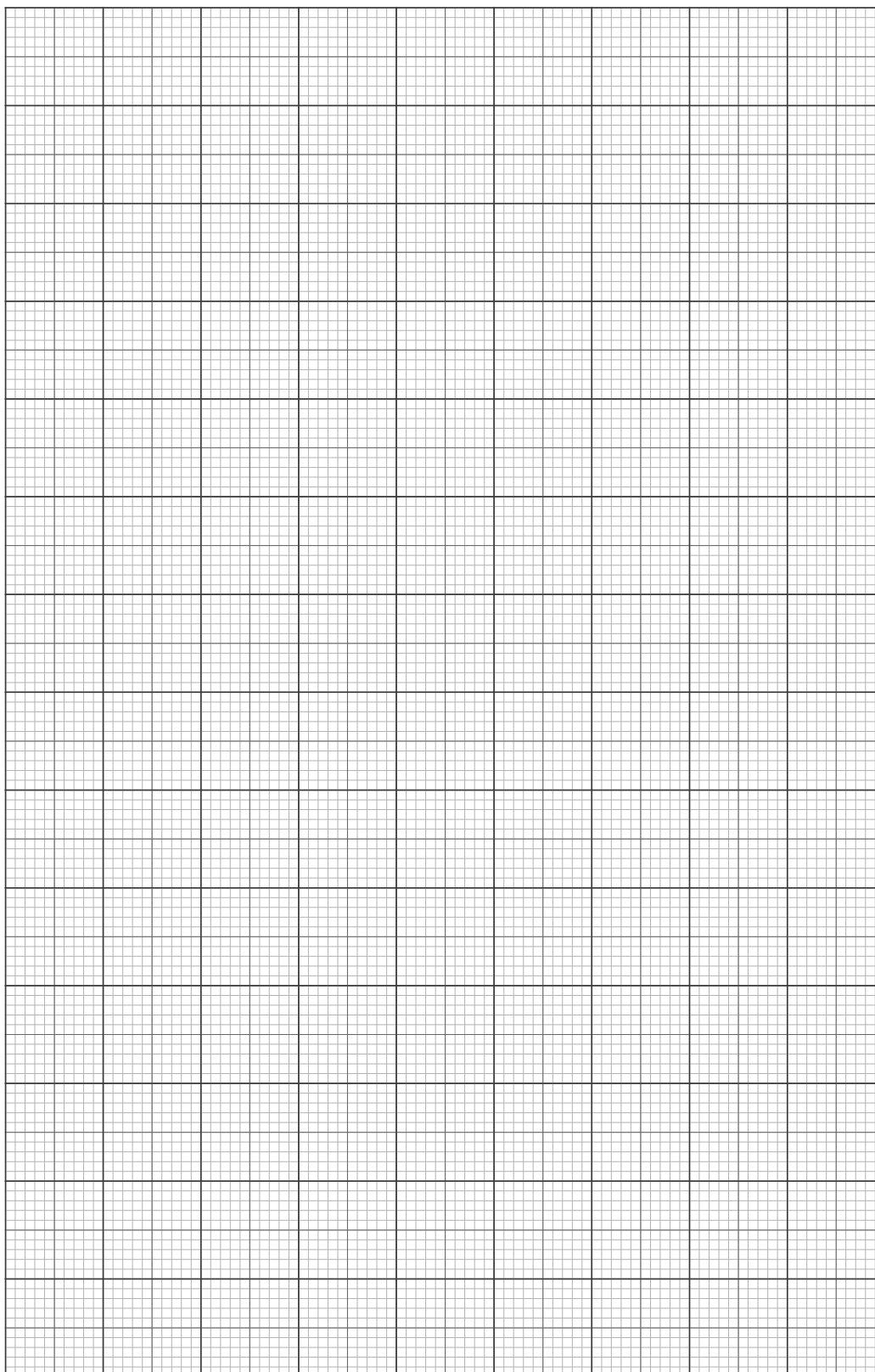

- (i) Determine the gradient of the line of best fit including units. Be sure to show how you calculated the gradient.

(2 marks)

- (j) From the gradient calculated in (g), determine the thermal conductivity of the glass.

(2 marks)

END OF SECTION THREE

END OF THE EXAMINATION

Extra Graph for question 12

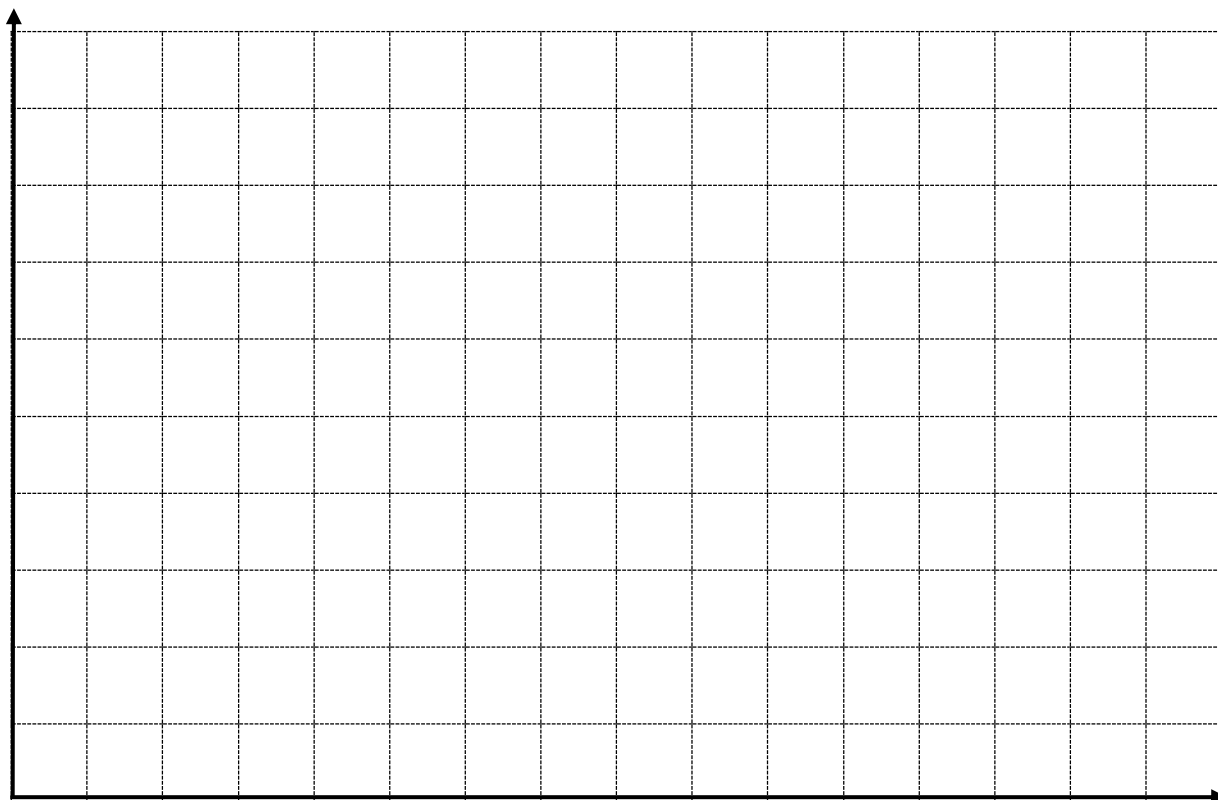

Extra Graph for question 18

Custom Graph

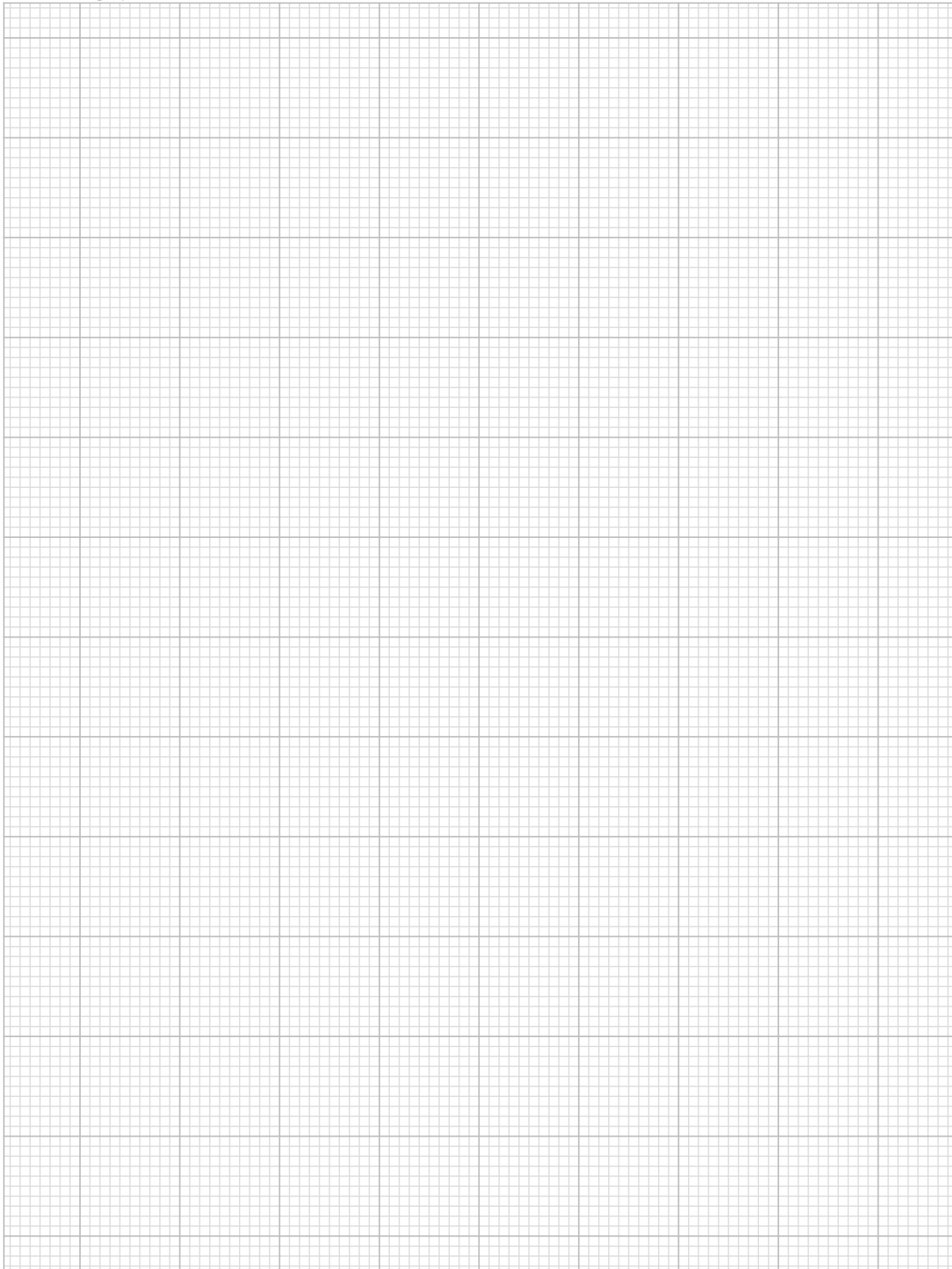

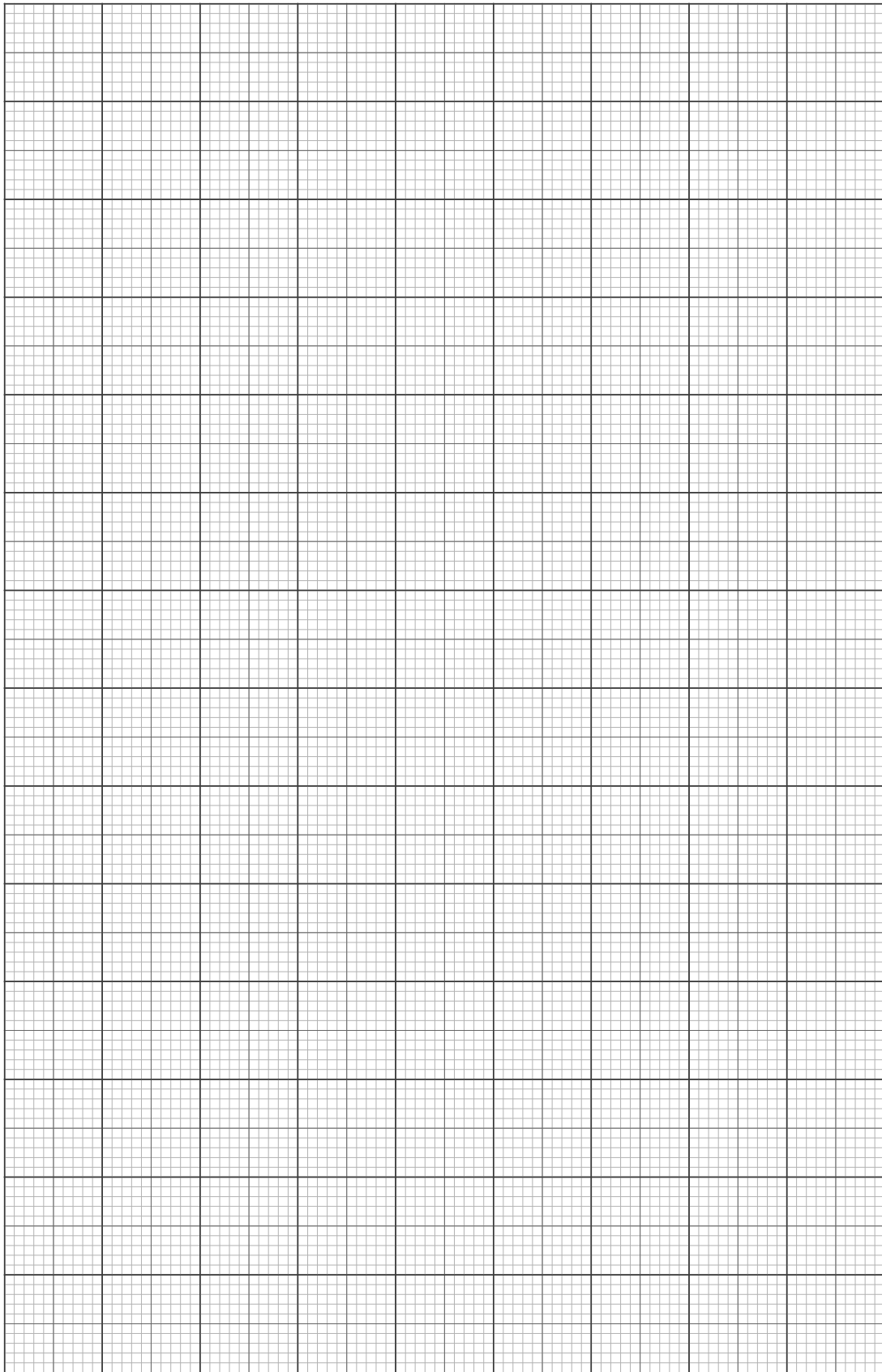

Acknowledgements

Question 7

Brain, M. and Elliott, S. (2019). *How Refrigerators Work*. [online] HowStuffWorks. Available at: <https://home.howstuffworks.com/refrigerator.htm> [Accessed 1 Feb. 2019].

Question 19

Brain, M. (2019). *How Smoke Detectors Work*. [online] HowStuffWorks. Available at: <https://home.howstuffworks.com/home-improvement/household-safety/smoke.htm> [Accessed 12 Jan. 2019].

WATP acknowledges the permission of School Curriculum and Assessment Authority in providing instructions to students.
